

INSTRUCTION MANUAL

ZH Test Set
Manual v0.1

ZERO-Hertz® Secondary Injection Test Set



Secondary Injection Test set for ZERO-Hertz® Trip Units

URC Utility Relay Company
UTILITYRELAY.COM

10100 QUEENS WAY
CHAGRIN FALLS, OH 44023
USA
888.289.2864

Table of Contents

	Page
1.0 Introduction.....	1
2.0 Basic Operation.....	1
3.0 Test Set Connections	2
3.1 Transducer Inputs.....	2
3.2 Shunt Inputs	2
4.0 Transducer Input Tests	3
4.1 Long-Time Tests	3
4.2 Short-Time Test.....	4
4.3 Instantaneous Test.....	4
4.4 Ground Fault Test	5
4.5 Reverse Current Test.....	6
5.0 Shunt Input Tests.....	7
5.1 Long-Time Test.....	7
5.2 Short-Time Test.....	9
5.3 Instantaneous Test.....	10
5.4 Reverse Current Test.....	10
Figure 1.....	11
Figure 2.....	12
Figure 3.....	13
Revision 0.1	

1.0 Introduction

The Model B-290 test set is specifically designed for secondary injection testing of the ZERO-Hertz DC trip unit.

Pick-up and multiple points on the time-current curves can be quickly tested using this test set.

The test set can perform pick-up and time delay trip tests for either the *transducer inputs* or the *shunt inputs* depending on the model ZERO-Hertz DC trip unit.

If the ZERO-Hertz DC trip unit is installed on a breaker, ***the breaker must be removed from service*** before secondary injection testing can be performed.

IMPORTANT

The Model B-290 test set is designed to test ZERO-Hertz DC trip units that are removed from service.

Secondary injection testing while the breaker is energized is extremely dangerous and should not be attempted.

2.0 Basic Operation of ZERO-Hertz DC Trip Unit

The ZERO-Hertz DC trip unit is micro-controller based and includes a 16-character liquid crystal display (LCD).

The trip unit provides the following protection functions:

- ?? Long Time (LT)
- ?? Short Time (ST)
- ?? Instantaneous (I)
- ?? Ground Fault (GF) (Transducer input only)
- ?? Reverse Current (RC)

The trip unit requires external power to operate. The Model B-290 test set provides the external power during testing.

For the *transducer input*:

- ?? The trip unit accepts inputs from either one or two breaker mounted transducers.
- ?? The trip unit calculates the current for each transducer separately and has independent trip registers for each.
- ?? The largest current is displayed on the LCD.
- ?? Reverse current is monitored on the "Plus" pole transducer only.
- ?? Ground fault current is determined as the numerical difference between the two transducer currents.
- ?? Ground fault is not available when using only one transducer input.

For the *shunt input*:

- ?? The trip unit accepts only one shunt input.
- ?? The secondary rating of the shunt can be 50 Milli-Volt or 100 Milli-Volt.
- ?? Ground fault is not available for shunt input.

The trip unit saves the trip data in its non-volatile EEPROM memory after a trip. This data is written over with the data from the next trip event.

A trip counter indicates how many times the trip unit operated on each function.

3.0 Test Set Connections

Figure 1 in the back of the manual provides an overview of the control panel on the B-290 ZERO-Hertz DC Test Set. The numbers in brackets [] appearing throughout this manual refer to the numbered controls in Figure 1.

Figures 2 and 3 in the back of the manual describe certain test set connections. The letters in brackets { } appearing throughout this manual refer to the letters in Figures 2 and 3.

POWER CABLE:

With the ON-OFF switch [2] in the OFF position, connect the power cable to the power connector on the test set [1] and plug into a 120Vac receptacle.

POWER & ACTUATOR CABLE:

Connect the Power & Actuator Cable to its' connector [3] on the test set.

Connect the power plug to the POWER INPUT {A} on the top of the trip unit.

Connect the actuator plug to the ACTUATOR connector {B} on the top of the trip unit.

3.1 Transducer Inputs

Connect the PLUS transducer cable from the PLUS connector [15] on the test set to the PLUS connector {C} on the trip unit.

Connect the MINUS transducer cable from the MINUS connector [16] on the test set to the MINUS connector {D} on the trip unit.

NOTE

If the trip unit also has a Shunt Input {E} connection, verify that “Xducer” is selected as the signal input to the trip unit when the trip unit is commissioned.

Refer to the ZERO-Hertz Instruction Manual Section 5.3 Transducer/Shunt Input Select

Do *not* connect the shunt cable when testing the transducer input.

Proceed to Section 4.0 and continue with Transducer Input Tests.

3.2 Shunt Inputs

When testing the shunt portion of a trip unit equipped with the shunt input option:

Connect the shunt cable to SHUNT CABLE connector [22] on the test set. Connect the other end of the shunt cable to the trip unit DC SHUNT INPUT {E}.

Make sure that the marking on the SHUNT CABLE lugs match the screw markings on the bottom of the trip unit.

NOTE

Before testing a trip unit with shunt input, verify that “SHUNT” is selected as the signal input to the trip unit when the trip unit is commissioned.

Refer to the ZERO-Hertz Instruction Manual Section 5.3 Transducer/Shunt Input Select

Do *not* connect the transducer cables when testing the shunt input.

Proceed to Section 5.0 and continue with Shunt Input Tests.

4.0 Transducer Input Tests

Set the TRANSDUCER/SHUNT SELECTOR switch [9] to transducer.

The TRANSDUCER INPUT LED [10] will illuminate.

4.1 Long-Time Test

LT Pick-Up “PLUS” Pole

Set the TRANSDUCER CABLE switch [14] to PLUS POLE and the CURRENT DIRECTION switch [11] to FORWARD.

If the Ground Fault trip function is turned ON in the trip unit, temporarily unplug the MINUS transducer cable [16]. Unplugging the MINUS cable automatically defeats the Ground Fault function.

Calculate the normalized LT Pick-Up setting by dividing the LT Pick-Up setting in the trip unit by the transducer rating set in the trip unit.

As an example, if the transducer rating is 600 amp and the LT Pick-Up is set at 450 amp, then the normalized LT Pick-Up setting is 0.75.

$$\frac{\text{LT Pick-Up}}{\text{Transducer rating}} = \frac{450}{600} = 0.75$$

Turn the CURRENT ADJUST knob [12] until the MILLI-AMP meter [13] displays a value slightly less than the calculated normalized LT Pick-Up setting.

Push the RESET button [8].

Push the START button [5].

Slowly turn the CURRENT ADJUST knob [12] clockwise until the PICK-UP LED on the trip unit is solidly on.

The value displayed on the MILLI-AMP meter [13] is the actual normalized LT Pick-Up of the trip unit.

Push the STOP button [7].

LT Pick-Up “MINUS” Pole

Set the TRANSDUCER CABLE switch [14] to the MINUS POLE and repeat the above procedure to test LT Pick-Up for the MINUS pole. If the Ground Fault trip function is turned ON in the trip unit, temporarily unplug the PLUS POLE transducer cable [15] to defeat Ground Fault.

LT Time Delay:

Set the TRANSDUCER CABLE switch [14] to PLUS POLE and the CURRENT DIRECTION switch [11] to FORWARD.

If the Ground Fault trip function is turned ON in the trip unit, temporarily unplug the "MINUS" transducer cable.

Calculate the desired normalized test current by dividing the desired test current in amps by the transducer rating set in the trip unit.

NOTE

If the ST, or I Pick-Up settings are less than the desired LT test current, then that function must temporarily be turned off or set to a higher value than the desired LT test current.

As an example, if the transducer rating is 600 amp and the desired test current is 1800 amp, then the normalized test current is 3.00.

$$\frac{\text{Test Current}}{\text{Transducer Rating}} = \frac{1800}{600} = 3.00$$

To accurately test the LT time delay, the test current must be at least 10% greater than the LT Pick-Up setting.

Turn the CURRENT ADJUST knob [12] until the MILLI-AMP meter [13] displays a value equal to the calculated normalized test current.

Push the RESET button [8].

Push the START button [5].

If the displayed value on the MILLI-AMP meter [13] changed slightly from the desired test current, quickly adjust the CURRENT ADJUST knob [12] until the desired value is displayed.

When the trip unit outputs a trip signal, the test current will turn off and the timer will stop.

Verify that the trip time displayed on the TIMER [4] is within the time band.

Repeat the above for the MINUS pole except that the TRANSDUCER CABLE switch [14] must be set to the MINUS POLE and the PLUS transducer cable must be temporarily unplugged if the Ground Fault trip function is turned ON in the trip unit.

4.2 Short-Time Test

ST Pick-Up:

If the Short-Time (ST) trip function is turned ON in the trip unit it can be tested as follows.

Set the TRANSDUCER CABLE switch [14] to PLUS POLE and the CURRENT DIRECTION switch [11] to FORWARD.

If the ground fault trip function is turned ON in the trip unit, temporarily unplug the MINUS POLE transducer cable.

Calculate the normalized ST Pick-Up setting by dividing the ST Pick-Up setting in the trip unit by the transducer rating set in the trip unit.

As an example, if the transducer rating is 600 amp and the ST Pick-Up is set at 3000 amp, then the normalized ST Pick-Up setting is 5.00.

$$\frac{\text{ST Pick-Up}}{\text{Transducer rating}} = \frac{3000}{600} = 5.00$$

Turn the CURRENT ADJUST knob [12] until the MILLI-AMP meter [13] displays a value slightly less than the calculated normalized ST Pick-Up setting.

Push the RESET button [8].

Push the START button [5].

Slowly turn the CURRENT ADJUST knob [12] clockwise until the trip unit trips and stops the test current.

The value displayed on the MILLI-AMP meter [13] when the trip unit trips, is the actual normalized ST Pick-Up of the trip unit.

Repeat the above for the MINUS pole except the TRANSDUCER CABLE switch [14] must be set to the MINUS POLE and the PLUS POLE transducer cable must be temporarily unplugged if the ground fault trip function is turned ON in the trip unit

ST Time Delay:

Set the TRANSDUCER CABLE switch [14] to PLUS POLE and the CURRENT DIRECTION switch [11] to FORWARD.

If the ground fault trip function is turned ON in the trip unit, temporarily unplug the MINUS POLE transducer cable.

Calculate the desired normalized test current by dividing the desired test current in amps by the transducer rating set in the trip unit.

As an example, if the transducer rating is 600 amp and the desired test current is 3600 amp, then the normalized test current is 6.00.

$$\frac{\text{Test Current}}{\text{Transducer Rating}} = \frac{3600}{600} = 6.00$$

To accurately test the ST time delay, the test current must be at least 10% greater than the ST Pick-Up setting.

Turn the CURRENT ADJUST knob [12] until the MILLI-AMP meter [13] displays a value equal to the calculated normalized test current.

Push the RESET button [8].

Push the START button [5].

When the trip unit outputs a trip signal, the test current will turn off and the timer will stop.

Verify that the trip time displayed on the TIMER [4] is within the time band.

NOTE

The Short-Time Function in the trip unit has an I²T option that is selectable ON/OFF. Refer to the ZERO-Hertz Instruction Manual for details regarding how this option can be used to customize the time band.

4.3 Instantaneous Test

I Pick-Up:

If the Instantaneous (I) trip function is turned ON in the trip unit it can be tested the same way that the ST Pick-Up was tested.

If the ST function is turned on in the trip unit, it must be temporarily turned OFF so it does not interfere with the I Pick-Up test.

4.4 Ground Fault Test

GF Pick-Up:

If the Ground Fault (GF) trip function is turned ON in the trip unit it can be tested as follows.

Set the TRANSDUCER CABLE switch [14] to PLUS POLE and the CURRENT DIRECTION switch [11] to FORWARD.

Calculate the normalized GF Pick-Up setting by dividing the GF Pick-Up setting in the trip unit by the transducer rating set in the trip unit.

As an example, if the transducer rating is 600 amp and the GF Pick-Up is set at 300 amp, then the normalized GF Pick-Up setting is 0.50.

$$\frac{\text{GF Pick-Up}}{\text{Transducer rating}} = \frac{300}{600} = 0.50$$

Turn the CURRENT ADJUST knob [12] until the MILLI-AMP meter [13] displays a value slightly less than the calculated normalized GF Pick-Up setting.

Push the RESET button [8].

Push the START button [5].

Slowly turn the CURRENT ADJUST knob [12] clockwise until the trip unit trips and stops the test current.

The value displayed on the MILLI-AMP meter [13] when the trip unit trips, is the actual normalized GF Pick-Up of the trip unit.

Repeat the above for the MINUS pole except the TRANSDUCER CABLE switch [14] must be set to the MINUS POLE.

GF Time Delay:

Set the TRANSDUCER CABLE switch [14] to PLUS POLE and the CURRENT DIRECTION switch [11] to FORWARD.

Calculate the desired normalized test current by dividing the desired test current in amps by the transducer rating set in the trip unit.

As an example, if the transducer rating is 600 amp and the desired test current is 420 amp, then the normalized test current is 0.70.

$$\frac{\text{Test Current}}{\text{Transducer Rating}} = \frac{420}{600} = 0.70$$

To accurately test the GF time delay, the test current must be at least 10% greater than the GF Pick-Up setting.

Turn the CURRENT ADJUST knob [12] until the MILLI-AMP meter [13] displays a value equal to the calculated normalized test current.

Push the RESET button [8].

Push the START button [5].

When the trip unit outputs a trip signal, the test current will turn off and the timer will stop.

Verify that the trip time displayed on the TIMER [4] is within the time band.

NOTE

The Ground Fault Function in the trip unit has an I²T option that is selectable ON/OFF. Refer to the ZERO-Hertz Instruction Manual for details regarding how this option can be used to customize the time band.

4.5 Reverse Current Test

RC Pick-Up:

If the Reverse Current (RC) trip function is turned ON in the trip unit it can be tested as follows.

Set the TRANSDUCER CABLE switch [14] to PLUS POLE and the CURRENT DIRECTION switch [11] to REVERSE.

Calculate the normalized RC Pick-Up setting by dividing the RC Pick-Up setting in the trip unit by the transducer rating set in the trip unit.

As an example, if the transducer rating is 600 amp and the RC Pick-Up is set at 300 amp, then the normalized RC Pick-Up setting is 0.50.

$$\frac{\text{RC Pick-Up}}{\text{Transducer rating}} = \frac{300}{600} = 0.50$$

Turn the CURRENT ADJUST knob [12] until the MILLI-AMP meter [13] displays a value slightly less than the calculated normalized RC Pick-Up setting.

Push the RESET button [8].

Push the START button [5].

Slowly turn the CURRENT ADJUST knob [12] clockwise until the trip unit trips and stops the test current.

The value displayed on the MILLI-AMP meter [13] when the trip unit trips, is the actual normalized RC Pick-Up of the trip unit.

NOTE

The Reverse Current Function in the trip unit only responds to the PLUS pole transducer (or the Shunt Input).

The Reverse Current Function *cannot* be tested on the MINUS pole. The TRANSDUCER CABLE switch [14] must be set to the PLUS POLE.

RC Time Delay:

Set the TRANSDUCER CABLE switch [14] to PLUS POLE and the CURRENT DIRECTION switch [11] to REVERSE.

Calculate the desired normalized test current by dividing the desired test current in amps by the transducer rating set in the trip unit.

As an example, if the transducer rating is 600 amp and the desired test current is 450 amp, then the normalized test current is 4.00.

$$\frac{\text{Test Current}}{\text{Transducer Rating}} = \frac{450}{600} = 0.75$$

To accurately test the RC time delay, the test current must be at least 10% greater than the RC Pick-Up setting.

Turn the CURRENT ADJUST knob [12] until the MILLI-AMP meter [13] displays a value equal to the calculated normalized test current.

Push the RESET button [8].

Push the START button [5].

When the trip unit outputs a trip signal, the test current will turn off and the timer will stop.

Verify that the trip time displayed on the TIMER [4] is within the time band.

NOTE

The Reverse Current Function in the trip unit has an I²T option that is selectable ON/OFF. Refer to the ZERO-Hertz Instruction Manual for details regarding how this option can be used to customize the time band.

5.0 Shunt Input Tests

Set the TRANSDUCER/SHUNT SELECTOR switch [9] to Shunt.

The SHUNT INPUT LED [17] will illuminate.

5.1 Long-Time Test

Verify that the test set is properly connected to the trip unit. See Figure 3. Also verify that both transducer cables are *disconnected*.

Testing 100mV Shunt Input:

Set the SHUNT SECONDARY RATING switch [21] to 100mV and the CURRENT DIRECTION switch [18] to FORWARD.

Calculate the normalized LT Pick-Up setting by multiplying the LT Pick-Up setting in the trip unit by 100mV and dividing by the shunt rating set in the trip unit.

As an example, if the shunt rating is 600 amp and the LT Pick-Up is set at 450 amp, then the normalized LT Pick-Up setting is 75mV.

$$\frac{\text{LT Pick-Up} \times 100\text{mV}}{\text{Shunt Rating}} = \frac{450 \times 100\text{mV}}{600} = 75\text{mV}$$

Turn the CURRENT ADJUST knob [19] until the MILLI-VOLTS meter [20] displays a value slightly less than the calculated normalized LT Pick-Up setting.

Push the RESET button [8].

Push the START button [5].

Slowly turn the CURRENT ADJUST knob [19] clockwise until the PICK-UP LED on the trip unit is solidly on.

The value displayed on the MILLI-VOLTS meter [20] is the actual normalized LT Pick-Up of the trip unit.

Push the STOP button [7].

Testing 50mV Shunt Input:

Set the SHUNT SECONDARY RATING switch [21] to 50mV and the CURRENT DIRECTION switch [18] to FORWARD.

Calculate the normalized LT Pick-Up setting by multiplying the LT Pick-Up setting in the trip unit by 50mV and dividing by the shunt rating set in the trip unit.

As an example, if the shunt rating is 600 amp and the LT Pick-Up is set at 450 amp, then the normalized LT Pick-Up setting is 37.5mV.

$$\frac{\text{LT Pick-Up} \times 50\text{mV}}{\text{Shunt Rating}} = \frac{450 \times 50\text{mV}}{600} = 37.5\text{mV}$$

Turn the CURRENT ADJUST knob [19] until the MILLI-VOLTS meter [20] displays a value slightly less than the calculated normalized LT Pick-Up setting.

Push the RESET button [8].

Push the START button [5].

Slowly turn the CURRENT ADJUST knob [19] clockwise until the PICK-UP LED on the trip unit is solidly on.

The value displayed on the MILLI-VOLTS meter [20] is the actual normalized LT Pick-Up of the trip unit.

Push the STOP button [7].

LT Time Delay for 100mV Input:

Set the SHUNT SECONDARY RATING switch [21] to 100mV and the CURRENT DIRECTION switch [18] to FORWARD.

Calculate the normalized test value by multiplying the desired test current by 100mV and dividing by the shunt rating set in the trip unit.

NOTE

If the ST, or I Pick-Up settings are less than the desired LT test current, then that function must temporarily be turned OFF or set to a higher value than the desired LT test current.

As an example, if the shunt rating is 600 amp and the desired test current is 1800 amp, then the normalized test value is 300mV.

$$\frac{\text{Test Current} \times 100\text{mV}}{\text{Shunt Rating}} = \frac{1800 \times 100\text{mV}}{600} = 300\text{mV}$$

To accurately test the LT time delay, the test current must be at least 10% greater than the LT Pick-Up setting.

Turn the CURRENT ADJUST knob [19] until the MILLI-VOLTS meter [20] displays a value equal to the calculated normalized test value.

Push the RESET button [8].

Push the START button [5].

If the displayed value on the MILLI-VOLTS meter [20] changed slightly from the desired test current, quickly adjust the CURRENT ADJUST knob [19] until the desired value is displayed.

When the trip unit outputs a trip signal, the test current will turn off and the timer will stop.

Verify that the trip time displayed on the TIMER [4] is within the time band.

LT Time Delay for 50mV Input:

Set the SHUNT SECONDARY RATING switch [21] to 50mV and the CURRENT DIRECTION switch [18] to FORWARD.

Calculate the normalized test value by multiplying the desired test current by 50mV and dividing by the shunt rating set in the trip unit.

NOTE

If the ST, or I Pick-Up settings are less than the desired LT test current, then that function must temporarily be turned OFF or set to a higher value than the desired LT test current.

As an example, if the shunt rating is 600 amp and the desired test current is 1800 amp, then the normalized test value is 150mV.

$$\frac{\text{Test Current} \times 50\text{mV}}{\text{Shunt Rating}} = \frac{1800 \times 50\text{mV}}{600} = 150\text{mV}$$

To accurately test the LT time delay, the test current must be at least 10% greater than the LT Pick-Up setting.

Turn the CURRENT ADJUST knob [19] until the MILLI-VOLTS meter [20] displays a value equal to the calculated normalized test value.

Push the RESET button [8].

Push the START button [5].

If the displayed value on the MILLI-VOLTS meter [20] changed slightly from the desired test current, quickly adjust the CURRENT ADJUST knob [19] until the desired value is displayed.

When the trip unit outputs a trip signal, the test current will turn off and the timer will stop.

Verify that the trip time displayed on the TIMER [4] is within the time band.

5.2 Short-Time Test

ST Pick-Up:

If the Short-Time (ST) trip function is turned ON in the trip unit it can be tested as follows.

Set the SHUNT SECONDARY RATING switch [21] to 100mV or 50mV and the CURRENT DIRECTION switch [18] to FORWARD.

Calculate the normalized ST Pick-Up setting by multiplying the ST Pick-Up setting by 100mV or 50mV and dividing by the shunt rating set in the trip unit.

As an example, if the shunt rating is 600 amp and the ST Pick-Up is set at 2400 amp, then the normalized ST Pick-Up setting is 400mV for 100mV shunt and 200mV for 50mV shunt.

$$\frac{\text{ST Pick-Up} \times 100\text{mV}}{\text{Shunt Rating}} = \frac{2400 \times 100\text{mV}}{600} = 400\text{mV}$$

OR

$$\frac{\text{ST Pick-Up} \times 50\text{mV}}{\text{Shunt Rating}} = \frac{2400 \times 50\text{mV}}{600} = 200\text{mV}$$

Turn the CURRENT ADJUST knob [19] until the MILLI-VOLTS meter [20] displays a value slightly less than the calculated normalized LT Pick-Up setting.

Push the RESET button [8].

Push the START button [5].

Slowly turn the CURRENT ADJUST knob [12] clockwise until the trip unit trips and stops the test current.

The value displayed on the MILLI-VOLTS meter [20] when the trip unit trips, is the actual normalized ST Pick-Up of the trip unit.

ST Time Delay:

Set the SHUNT SECONDARY RATING switch [21] to 100mV or 50mV and the CURRENT DIRECTION switch [18] to FORWARD.

Calculate the normalized test value by multiplying the desired test current by 100mV or 50mV and dividing by the shunt rating set in the trip unit.

As an example, if the shunt rating is 600 amp and the desired test current is 3000 amp, then the normalized test value is 500mV for 100mV shunt and 250mV for 50mV shunt.

$$\frac{\text{Test Current} \times 100\text{mV}}{\text{Shunt Rating}} = \frac{3000 \times 100\text{mV}}{600} = 500\text{mV}$$

Or

$$\frac{\text{Test Current} \times 50\text{mV}}{\text{Shunt Rating}} = \frac{3000 \times 50\text{mV}}{600} = 250\text{mV}$$

To accurately test the ST time delay, the test current must be at least 10% greater than the LT Pick-Up setting.

Turn the CURRENT ADJUST knob [19] until the MILLI-VOLTS meter [20] displays a value equal to the calculated normalized test value.

Push the RESET button [8].

Push the START button [5].

When the trip unit outputs a trip signal, the test current will turn off and the timer will stop.

Verify that the trip time displayed on the TIMER [4] is within the time band.

NOTE

The Short-Time Function in the trip unit has an I²T option that is selectable ON/OFF. Refer to the ZERO-Hertz Instruction Manual for details regarding how this option can be used to customize the time band.

5.3 Instantaneous Test

I Pick-Up:

If the Instantaneous (I) trip function is turned ON in the trip unit it can be tested the same way that the ST Pick-Up was tested.

If the ST function is turned ON in the trip unit, it must be temporarily turned OFF so it does not interfere with the I Pick-Up test.

5.4 Reverse Current Test

RC Pick-Up:

If the Reverse Current (RC) trip function is turned ON in the trip unit it can be tested as follows.

Set the SHUNT SECONDARY RATING switch [21] to 100mV or 50mV and the CURRENT DIRECTION switch [18] to REVERSE.

Calculate the normalized RC Pick-Up setting by multiplying the RC Pick-Up setting by 100mV or 50mV and dividing by the shunt rating set in the trip unit.

As an example, if the shunt rating is 600 amp and the RC Pick-Up is set at 450 amp, then the normalized RC Pick-Up setting is 75mV for 100mV shunt and 37.5mV for 50mV shunt.

$$\frac{\text{RC Pick-Up} \times 100\text{mV}}{\text{Shunt Rating}} = \frac{450 \times 100\text{mV}}{600} = 75\text{mV}$$

Or

$$\frac{\text{RC Pick-Up} \times 50\text{mV}}{\text{Shunt Rating}} = \frac{450 \times 50\text{mV}}{600} = 37.5\text{mV}$$

Turn the CURRENT ADJUST knob [19] until the MILLI-VOLTS meter [20] displays a value slightly less than the calculated normalized RC Pick-Up setting.

Push the RESET button [8].

Push the START button [5].

Slowly turn the CURRENT ADJUST knob [12] clockwise until the trip unit trips and stops the test current.

The value displayed on the MILLI-VOLTS meter [20] when the trip unit trips, is the actual normalized RC Pick-Up of the trip unit.

RC Time Delay:

Set the SHUNT SECONDARY RATING switch [21] to 100mV or 50mV and the CURRENT DIRECTION switch [18] to REVERSE.

Calculate the normalized test value by multiplying the desired test current by 100mV or 50mV and dividing by the shunt rating set in the trip unit.

As an example, if the shunt rating is 600 amp and the desired test current is 1200 amp, then the normalized test value is 200mV for 100mV shunt and 100mV for 50mV shunt.

$$\frac{\text{Test Current} \times 100\text{mV}}{\text{Shunt Rating}} = \frac{1200 \times 100\text{mV}}{600} = 200\text{mV}$$

Or

$$\frac{\text{Test Current} \times 50\text{mV}}{\text{Shunt Rating}} = \frac{1200 \times 50\text{mV}}{600} = 100\text{mV}$$

To accurately test the RC time delay, the test current must be at least 10% greater than the RC Pick-Up setting.

Turn the CURRENT ADJUST knob [19] until the MILLI-VOLTS meter [20] displays a value equal to the calculated normalized test value.

Push the RESET button [8].

Push the START button [5].

When the trip unit outputs a trip signal, the test current will turn off and the timer will stop.

Verify that the trip time displayed on the TIMER [4] is within the time band.

NOTE

The Reverse Current Function in the trip unit has an I²T option that is selectable ON/OFF. Refer to the ZERO-Hertz Instruction Manual for details regarding how this option can be used to customize the time band.

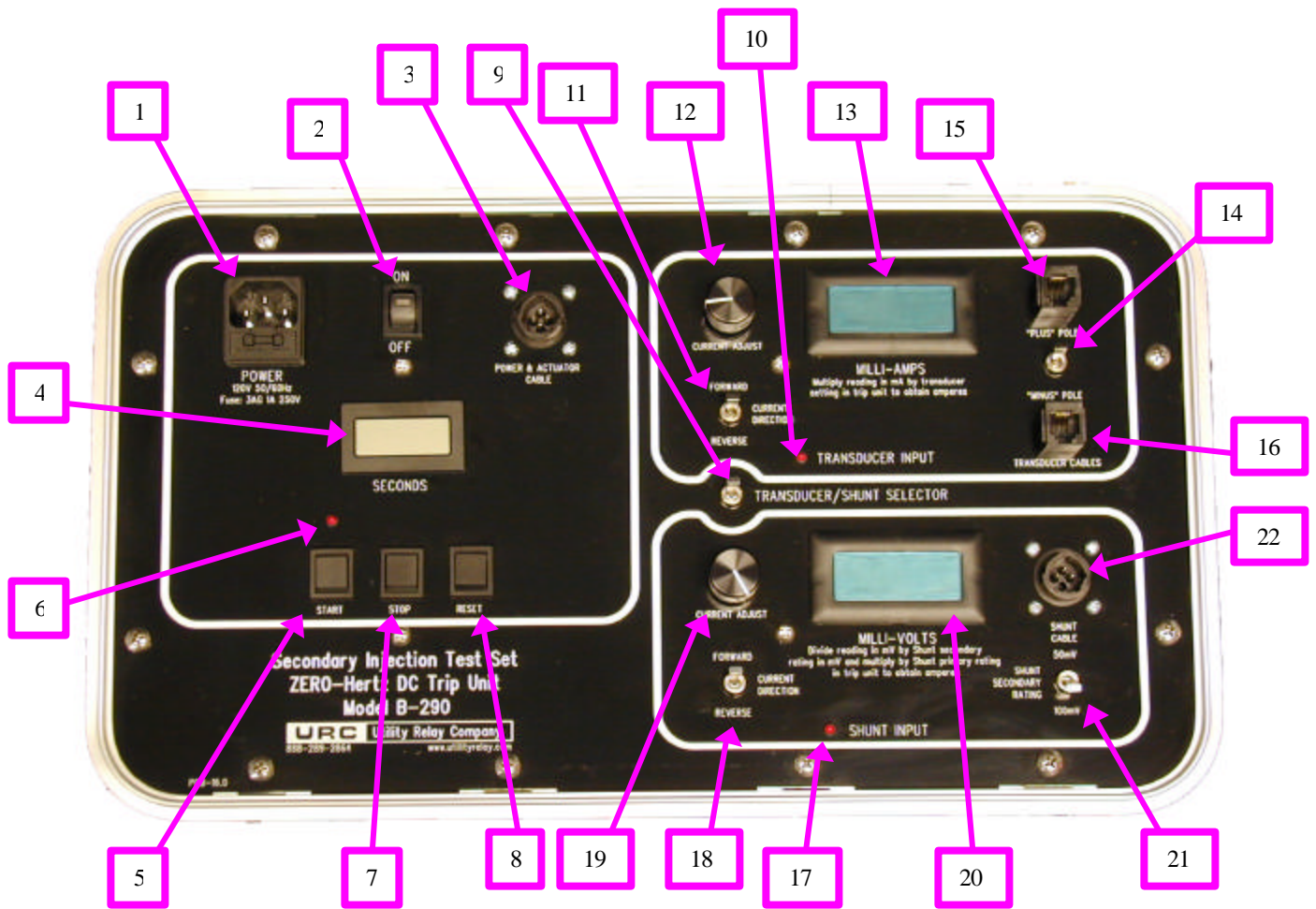

- | | | |
|--|--|---|
| <p>1 POWER CABLE
Power cable connector with main fuse. (120Vac 50/60Hz).</p> <p>2 ON-OFF SWITCH</p> <p>3 POWER & ACTUATOR CABLE
Connector for the trip unit power and actuator cable.</p> <p>4 TIMER</p> <p>5 START
Energizes the trip unit signal input and starts the timer.</p> <p>6 TEST LED
On whenever the test is in process.</p> <p>7 STOP
De-energizes the trip unit signal input and stops the timer.</p> <p>8 RESET
Resets the timer and the signal input after a trip signal from the trip unit.</p> | <p>9 TRANSDUCER/SHUNT SELECTOR
Selects either transducer input or shunt input.</p> <p>10 TRANSDUCER INPUT LED
On when set for transducer input.</p> <p>11 FORWARD/REVERSE SELECTOR
Current direction selector switch for transducer input.</p> <p>12 CURRENT ADJUST -TRANSUCER
Multi-turn adjustment for transducer test current.</p> <p>13 MILLI-AMP METER
Multiply Milli-Amp meter reading by transducer setting in trip unit to obtain primary amps.</p> <p>14 TRANSDUCER CABLE SELECTOR
Selects "Plus" pole or "Minus" pole transducer cable for test.</p> <p>15 "PLUS" POLE
Connector for "Plus" pole transducer.</p> <p>16 "MINUS" POLE
Connector for "Minus" pole transducer.</p> | <p>17 SHUNT INPUT LED
On when set for shunt input.</p> <p>18 FORWARD/REVERSE SELECTOR
Current direction selector switch for shunt input.</p> <p>19 CURRENT ADJUST -SHUNT
Multi-turn adjustment for shunt test current.</p> <p>20 MILLI-VOLT METER
Divide Milli-Volt meter reading by either 50 or 100 (depending on switch 21 position) and multiply by shunt setting in trip unit to obtain primary amps.</p> <p>21 SHUNT SECONDARY RATING
Selects 50 Milli-Volt or 100 Milli-Volt shunt input.</p> <p>22 SHUNT CABLE
Connector for shunt cable.</p> |
|--|--|---|

Figure 1
Control Panel Overview

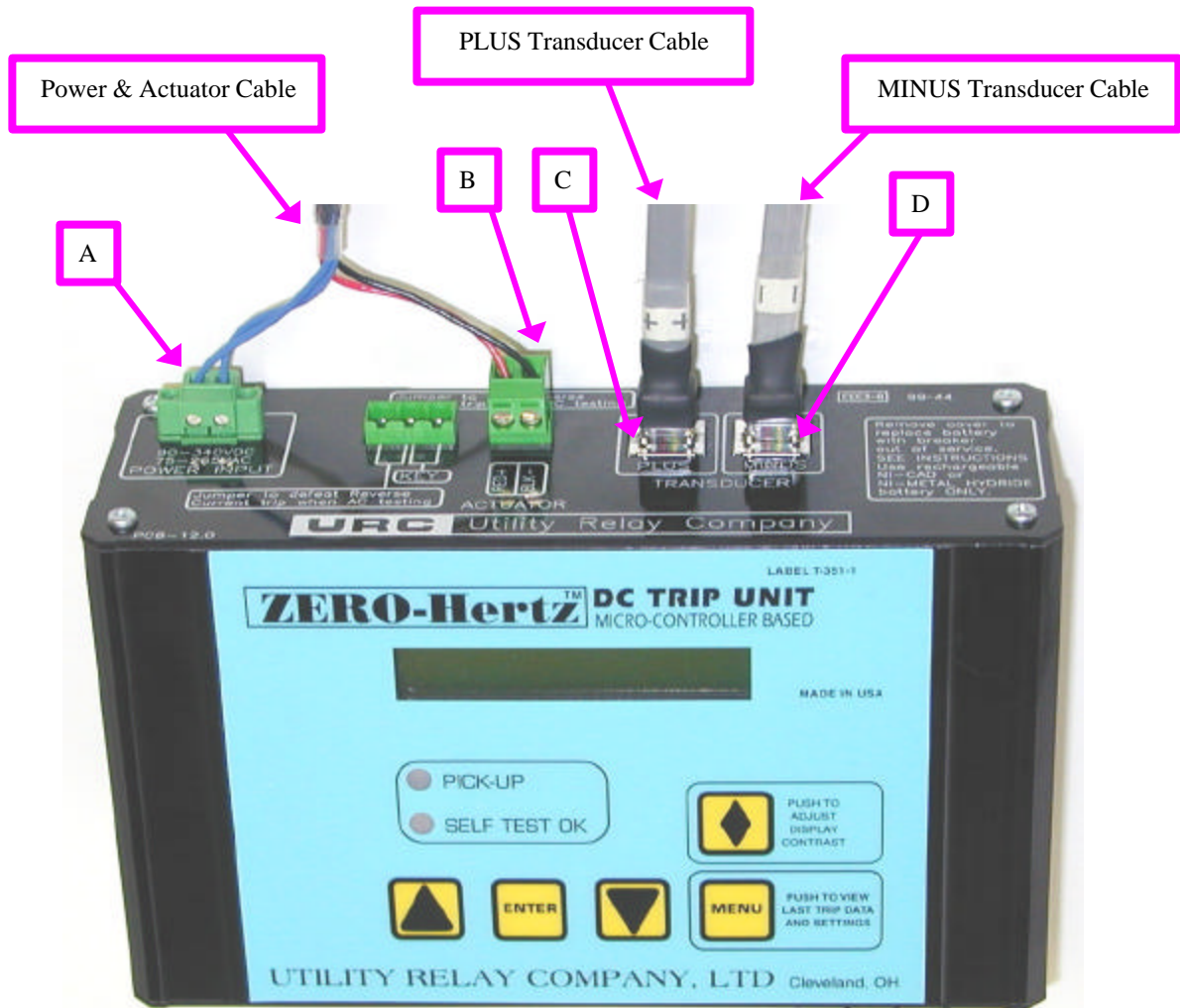

- A POWER CONNECTOR
- B ACTUATOR CONNECTOR
- C PLUS POLE TRANSDUCER CONNECTOR
- D MINUS POLE TRANSDUCER CONNECTOR

Figure 2
Transducer Test Set Connections

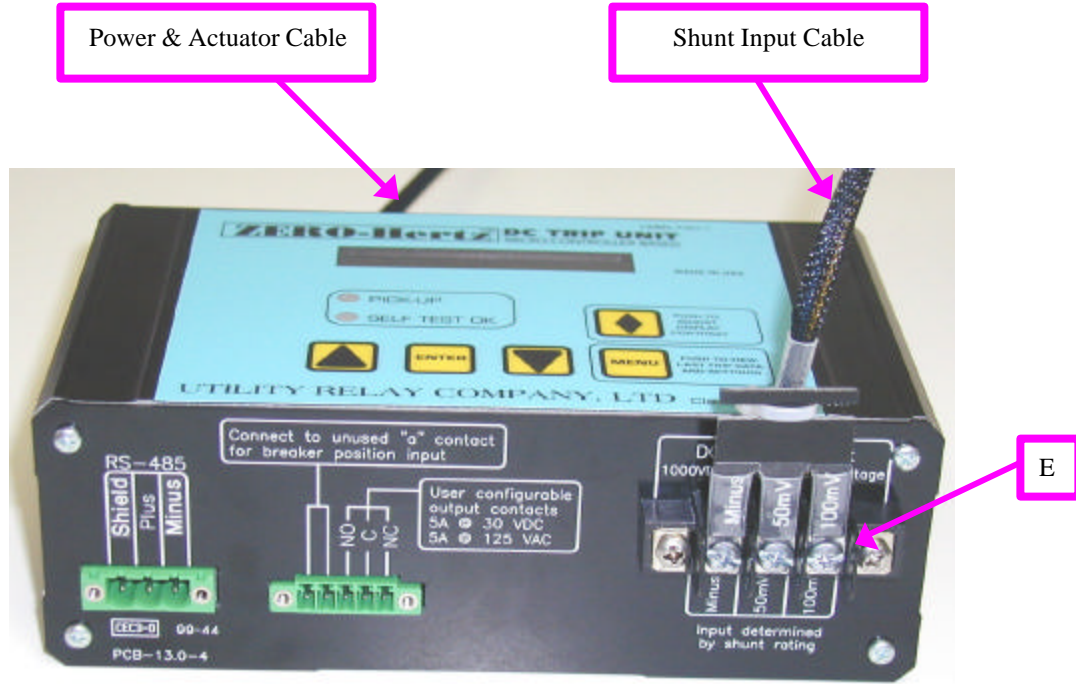

E SHUNT INPUT CONNECTOR

**Figure 3
Shunt Input Test Set Connections**

UTILITYRELAY.COM



I-ZERO-HERTZ-TS

URC Utility Relay Company

10100 QUEENS WAY
CHAGRIN FALLS, OH 44024
USA
888.289.2864